

1.0 Introduction

Thank you for purchasing of this Watch. Your Watch features electronic sensors which measures and shows the outdoor conditions: weather forecast, temperature, air pressure, altitude and compass directions.

Your Watch also provides the essential information about your body during exercise, like walking steps, traveling speed, distance, etc.

Your Watch also includes current time, daily alarm, timer and world time function.

To get the most of your purchase, it is advisable to use this Watch in conformity with the below notes:

- Be sure to carefully read this manual and keep it on hand for later reference when necessary.
- Avoid exposing your Watch to extreme conditions for an unreasonable time.
- Avoid rough usages or severe impacts to your Watch.
- Do not open the Watch's case unless a certified service agency because your Watch contains precise electronic sensors and components.
- Clean your Watch with a soft cloth occasionally that working for a longer use life of your watch.
- Keep your Watch away from magnets or the appliances which contains magnetic objects such as mobile phones, speakers and motors.
- Store your Watch in a dry place when it is not in use.

2.0 Button Layout

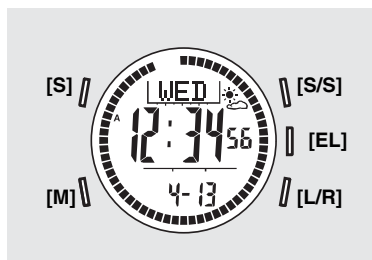

Mode Button [M]

- To select among Current Time, Daily Alarm, Timer and World Time Mode.
- To select among the setting items under setting display.

Sensor button [S]

- To select between timekeeping and sensor menu.
- To select between Trip, Barometer and Compass mode in sensor menu.

Start/Stop Button [S/S]

- To activate the 'start' or 'stop' function under Timer and Trip Mode.
- To select the current city time
- To increase the setting value under setting display.

Lap/Reset Button [L/R]

- To activate the 'Reload' function under Timer Mode (stop counting).
- To decrease the setting value under setting display.

Back light Button [EL]

- To turn on the EL back light for about 3 seconds.

3.0 Major Function Mode - Timekeeping and Sensor Mode

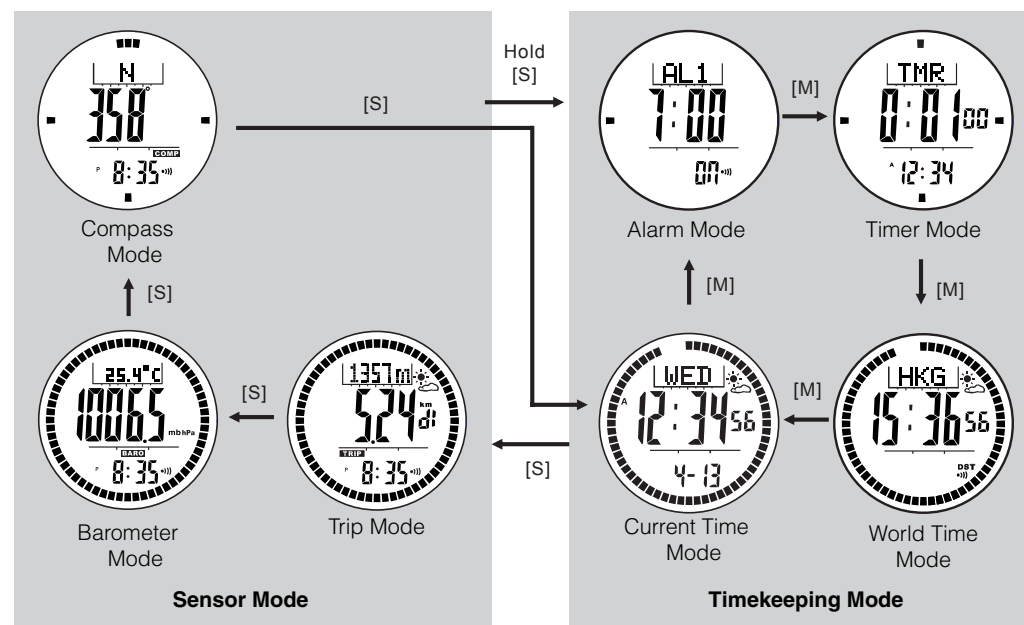

2.0 Button Layout

4.0 Current Time Mode - Function Display

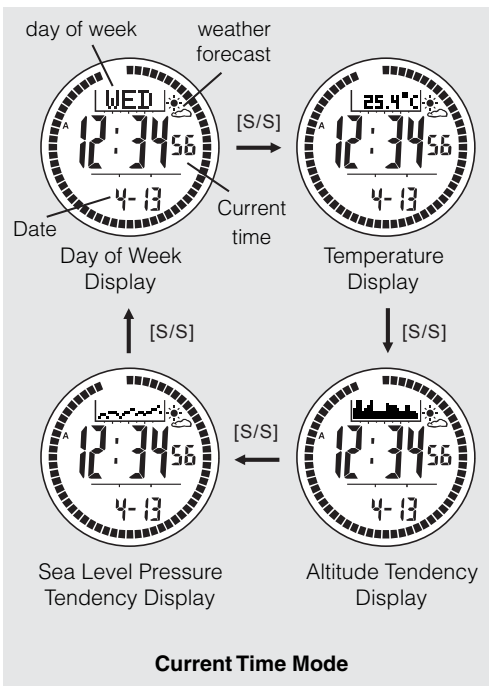

Functional Display

- The Current Mode includes 4 kinds of functional display:
 - Day of Week Display
 - Temperature Display
 - Altitude Tendency Display and
 - Sea Level Pressure Tendency Display
- To select among different functional display, press the [S/S] button following the adjacent diagram.

4.1 Current Time Mode - Weather Forecast Feature

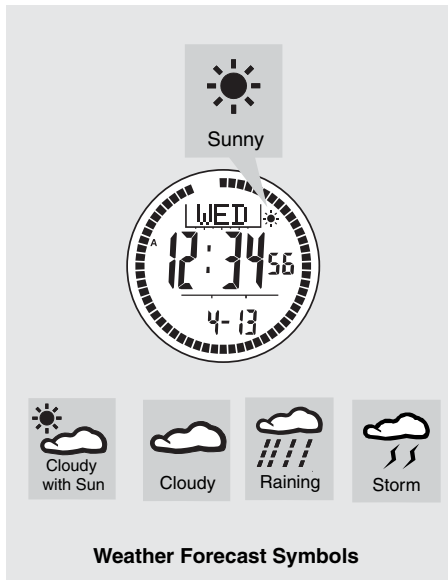

Weather Forecast Feature

A special feature of the Watch is the coming weather predicting function. It works by analyzing the changes of the past air pressure.

How to Indicate the Coming Weather

The Watch provides 5 different symbols to indicate the forecast weather, which includes:

- Sunny
- Cloudy with Sun
- Cloudy
- Raining
- Storm

The symbols will be shown only in Current Time Mode and World Time Mode.

IMPORTANT: Since the Watch predicts the coming weather by using the data of the changes in the air pressure, it is highly recommended to stay at the same altitude for at least 24 hours for a higher accuracy prediction.

IMPORTANT: The Watch predicts the weather by adopting general weather prediction principles, it is NOT capable to reflect the dramatic changing of weather within a very short period of time.

Note: To allow storm prediction, see 7.1 to set storm alert On/Off.

4.2 Current Time Mode - Setting the Current Time

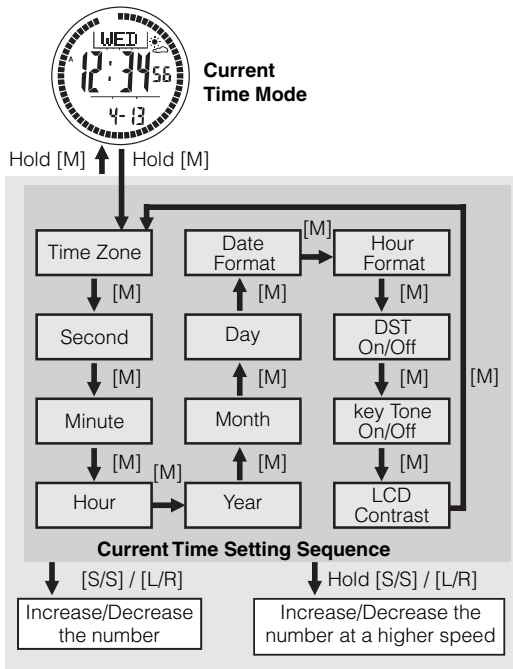

How to Set Current Time

- To select the setting display, press and hold the [M] button for about 2 seconds in Current Time Mode. In setting display, the flashing "SET" icon will appear.
- In setting display, press the [M] button to change the selection following the adjacent Current Time Setting Sequence.
- When the digits are flashing (selected), press the [S/S] or [L/R] button to increase / decrease the number. (Hold down the button change the number at a higher speed).
- When the setting is completed, press and hold the [M] button to exit the setting display.

5.0 Daily Alarm Mode - Daily Alarm 1, Daily Alarm 2 and Chime Display

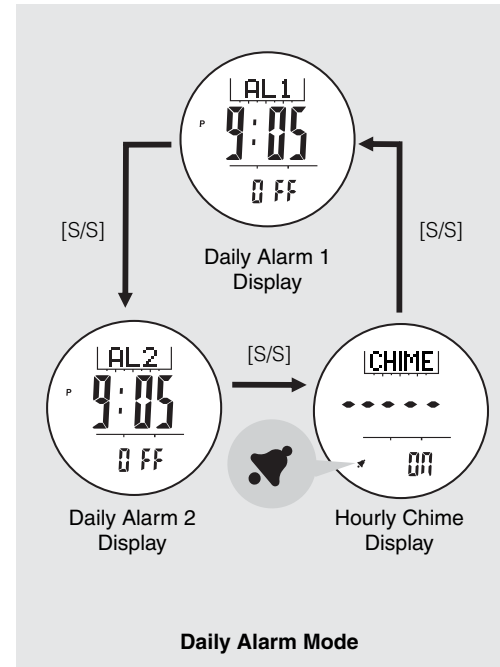

Daily Alarm 1 and Daily Alarm 2

- The Watch includes two daily alarms: Daily Alarm 1 and Daily Alarm 2. The Daily Alarm 1 and Daily Alarm 2 are working independently.
- Press the [S/S] button to switch among the Daily Alarm 1, Daily Alarm 2 and Chime Display following the adjacent diagram.

How to Turn ON/OFF the Daily Alarm

- To turn ON/OFF the Daily Alarm 1 (2), press the [L/R] button in Daily Alarm 1 (2) Display.
- When the Daily Alarm 1 (2) is ON, the alarm indicator '●●)' will appear.
- If the alarm indicator is appeared, the Watch will sound at the preset alarm time every day. When the alarm sounds, press any button to stop the beep.

How to Turn ON/OFF the Hourly Chime

- To turn ON/OFF the Hourly Chime, press the [L/R] button in Chime Display.
- When the chime is ON, the Chime indicator '🔔' will appear. If the Chime indicator is appeared, the Watch will beep once at the hour every hour.

5.1 Daily Alarm Mode - Setting the Alarm

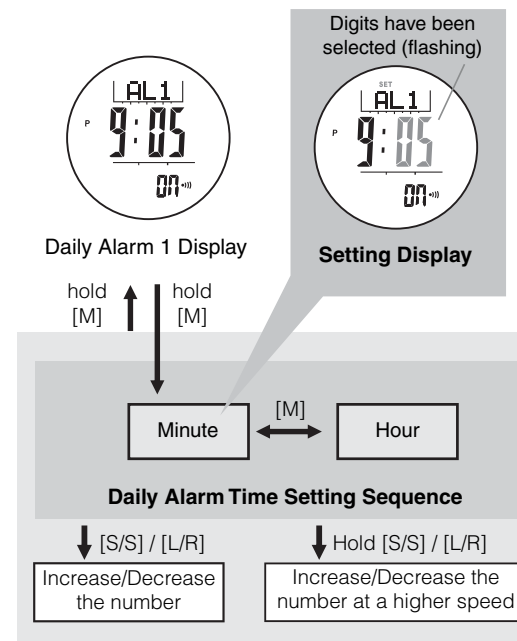

How to Set the Alarm 1 and Alarm 2

- To select the setting display, hold the [M] button for about 2 seconds in Alarm 1 (2) Display, then the flashing "SET" icon will appear.
- In setting display, press the [M] button to change the selection between minute and hour.
- When the digits are flashing (selected), press the [S/S] or [L/R] button to increase / decrease the number. (Hold down the button change the number at a higher speed).
- When the set is completed, press and hold the [M] button to exit the setting display.

6.0 Trip Mode - Function Display

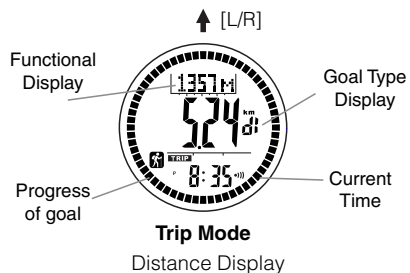
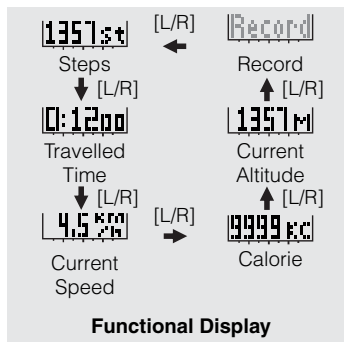

Main Trip Display

- The Trip Mode includes 3 kinds of Goal Type display:
 - Distance Display
 - Step Display
 - Calories Display
- See Trip Setting mode to select Goal Type display

Functional Display

- The Trip Mode includes 6 kinds of functional display:
 - Steps Display
 - Travelled Time Display
 - Current Speed Display
 - Calories Display
 - Current Altitude Display and
 - Record Display
- To select among different functional display, press the [L/R] button following the adjacent diagram.

Note: If Distance / Step / Calories are selected in Goal Type display, functional display will not be shown again in the upper row.

6.2 Trip Mode - Setting



Trip Mode
Hold [M] ↑ Hold [M]

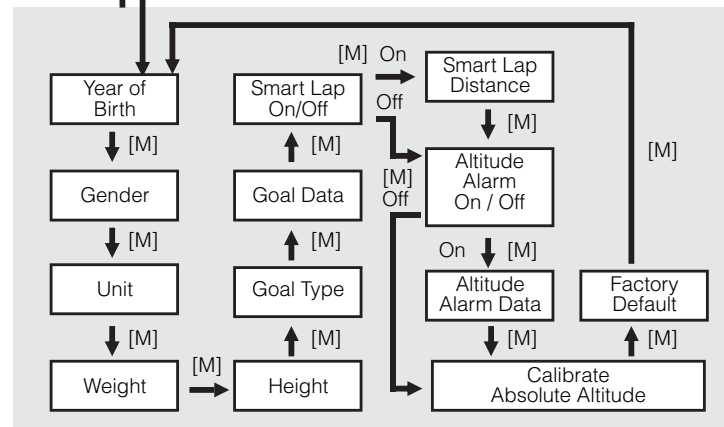

How to Set Trip Mode

- Press and hold [M] to enter Trip mode setting.
 - Press [M] to select among the settings.
 - If altitude alert is set On, when the current altitude is equal to or higher than the preset altitude level, the watch starts beeping for about 10 seconds and "▲" icon starts flashing.
 - After the first beeping, the watch will beep again for every 2 minutes if the current is still equal or higher than the preset value.
- Note:** Altitude alarm will be sounded in Trip Mode only.

6.1 Trip Mode - Using the Trip function

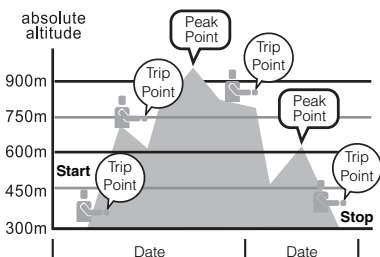

How to Start/Stop Trip Mode

- The watch has a built-in 3-axis accelerometer sensor which monitors and records your physical activity. One of the 3 types (Steps, Distance and Calories) can be selected as the trip goal and display on the watch.
- In Trip Mode, press [S/S] to start. Press [S/S] once again to stop.
- When Trip Mode start "Start" will appear and "▲" icon will start flashing.
- During the Trip, Highest Peak point will save to peak record automatically when Trip mode is activated.

How to Reset Trip Mode

- When Trip Mode is stopped, press and hold [L/R] to reset.
- All the previous Trip record data will be erased.

How to Record Trip Point Data

- When Trip Mode is started, press and hold [L/R] to save your trip point record, "Save!" will appear.
- Max 30 Trip point data can be saved and recall.
- If smart lap by distance is On, the watch will save your trip point record at preset distance interval.
- See Trip record recall to check the Trip Point Data.

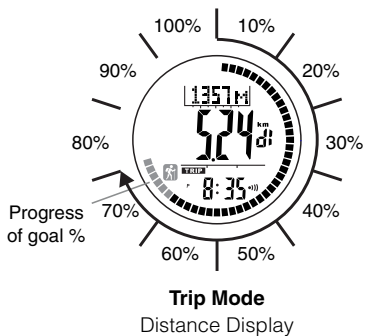

Note: Personal data such as Birthday, Gender, Height and Weight have to be input to get more accurate estimation of distance and calories burnt.

6.3 Trip Mode - Trip Record Recall (Highest peak record)

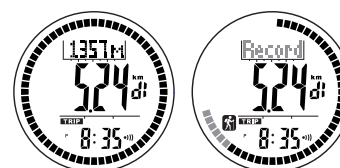

Trip Mode
Distance View Display

Trip Mode
Record View Display

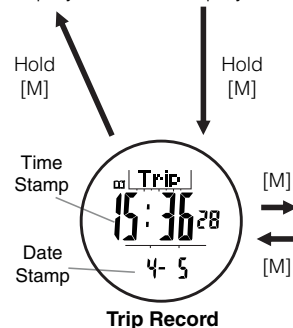

Highest Peak record

- Max 10 highest Peak record can be recall.
- In Trip Mode - Record View display, Press and hold [M] to enter Trip Record Recall Mode, Press [M] to enter highest peak record. Press [L/R] to select between 1 - 10 highest peak record.
- In Highest Peak Record view, press [S/S] to select between time date stamp and altitude view.

To Reset Highest Peak Record

- In Highest Peak Record View, Press and Hold [L/R] to reset Peak records.

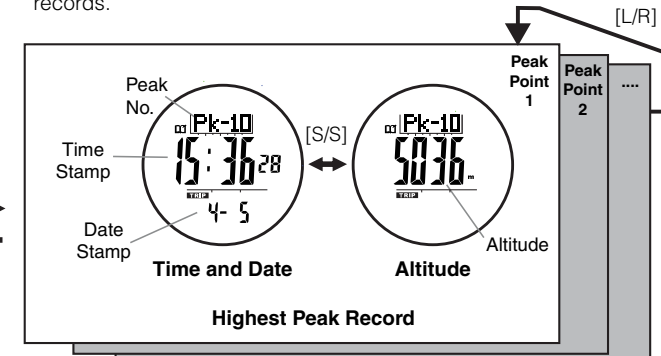

6.4.0 Trip Mode - Trip Record Recall (Trip Point Data)

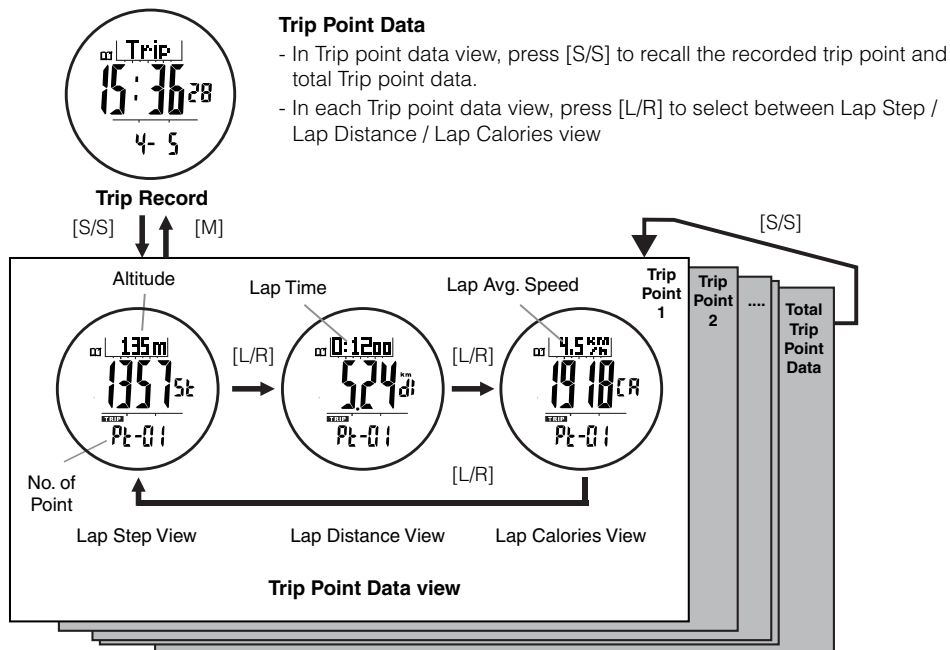

6.4.1 Trip Mode - Trip Record Recall (Trip Point Data)

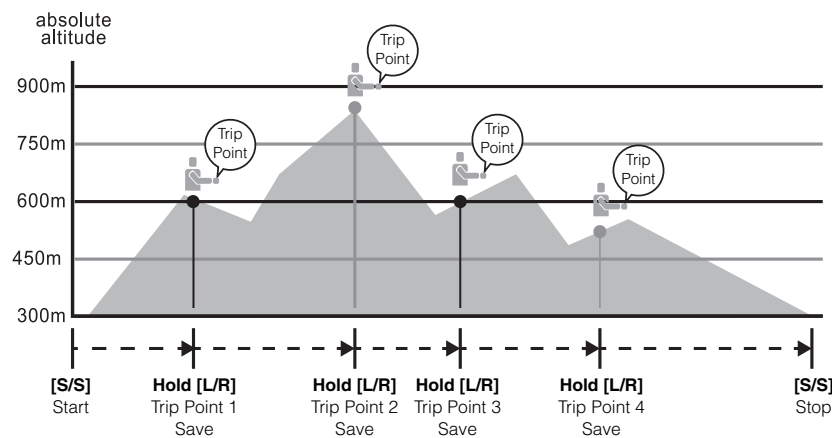

Trip Point Data

- The watch will record Absolute Altitude, Lap Step, Lap Distance, Lap Time, Lap Calories Burnt and Lap Average Speed in each Trip Point Data.
- In Total Trip Point data view: Total Step, Total Traveled Distance, Total Calories Burnt, Total Traveled Time, Total Average Speed and Final Trip Point Altitude.

6.5 Trip Mode - Trip Record Recall (Trip Total Data)

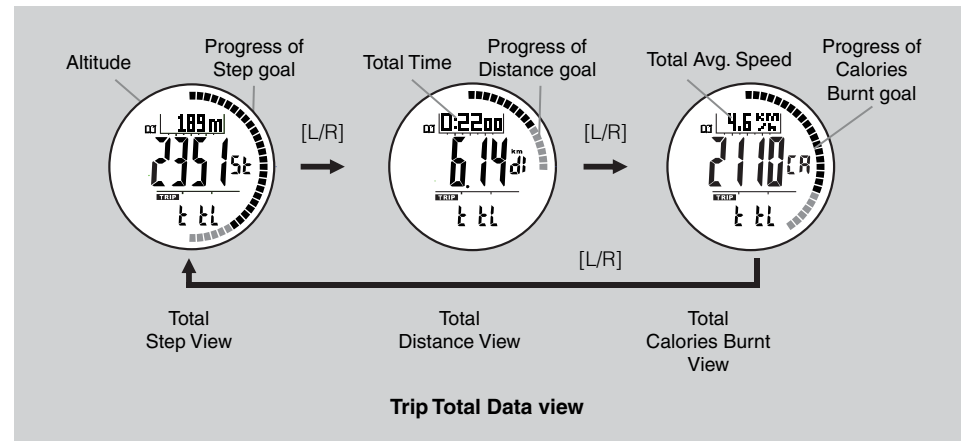

Trip Point Data

- In Total Trip point data view, press [L/R] to select between Total Step / Total Distance / Total Calories view
- Press [M] to exit Total trip point data view
- Press and hold [M] to exit trip recall mode

7.0 Barometer Mode- Function Display

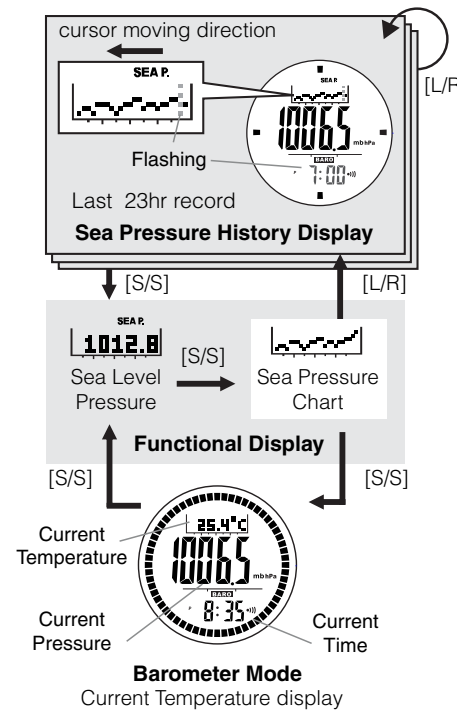

Functional Display

- The Barometer Mode includes 3 kinds of Functional display:
 - Current Temperature Display
 - Sea Level Pressure Display
 - Sea Pressure Chart Display
- Press and hold [S/S] to select Temperature / Baro Unit:



Sea Pressure History Display

- The watch records the sea pressure in every hour
- In Sea Pressure Chart display, press [L/R] to enter Sea pressure history display.
- Press [L/R] to move cursor left cyclically, then the respective pressure record will appear on the display

Note: If you want to have an accurate reading of air temperature, you must remove the watch from the wrist (for 20 - 30 minutes) that allows no body temperature effect on your watch.

7.1 Barometer Mode- Setting



Barometer Mode
Current Temperature display

↑ ↓ Hold [M]

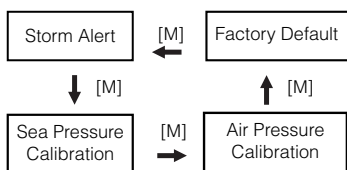

Barometer Setting Sequence

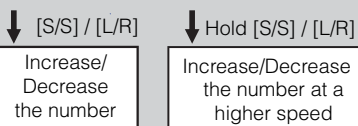

Barometer setting

- In Barometer mode, press and hold [M] to enter setting mode. Press [M] to select among the settings.
- When Storm alert is ON, 30 second beep alert will be given and "☁" will shown in Current and World time mode when the watch predicts the upcoming weather is stormy.
- Before calibrate the sea level pressure, consult the nearest observatory to get the sea and air pressure of your current position.

Important: Storm alert is triggered when pressure drops quickly with a certain period of time. But sometimes, a very fast pressure changes maybe due to altitude changes. This pressure changes due to altitude variation may result in exactly the same pattern as storm alert false alarm may occur.

Note:

- Input an incorrect pressure during the adjustment procedure may results an incorrect pressure reading in the future.

8.1 Compass Mode - Compass Directions and Bearings

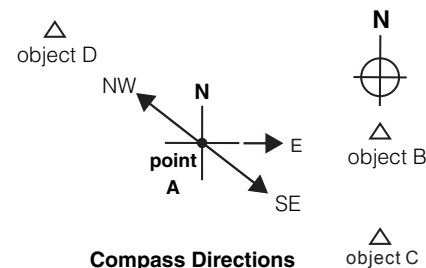

Compass Directions

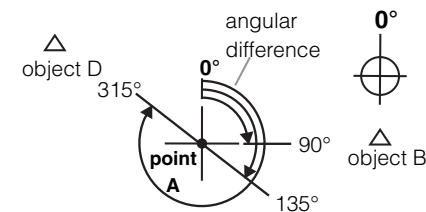

Compass Bearings

Marks	Compass Directions	Compass Bearing
N	North	349° - 11°
NNE	North Northeast	12° - 33°
NE	Northeast	34° - 56°
ENE	East Northeast	57° - 78°
E	East	79° - 101°
ESE	East Southeast	102° - 123°
SE	Southeast	124° - 146°
SSE	South Southeast	147° - 168°
S	South	169° - 191°
SSW	South Southwest	192° - 213°
SW	Southwest	214° - 236°
WSW	West Southwest	237° - 258°
W	West	259° - 281°
WNW	West Northwest	282° - 303°
NW	Northwest	304° - 326°
NNW	North Northwest	327° - 348°

NOTE:

- This Watch includes both compass directions and compass bearings.

8.0 Compass Mode - Tips and Precautions

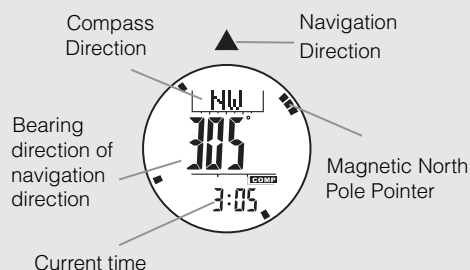

Compass Mode

Keep the Watch away from Magnetic sources, like:

- Speakers,
- Motors,
- Mobile phones and etc.

Avoid measuring direction when:

- Close to a magnetic object
- Close to metallic object
- Close to an electrical appliance
- Inside a moving object.

Perform compass calibration or magnetic declination compensation process when:

- The Watch is using for the first time,
- The battery has been replaced,
- The bearing direction digits are flashing, and the compass bearing and compass direction are flashing
- The compass uses in a location that is apart from the place in which the compass had been calibrated,
- The user intends to regulate the precision of the digital compass.

8.2 Compass Mode - Compass Display

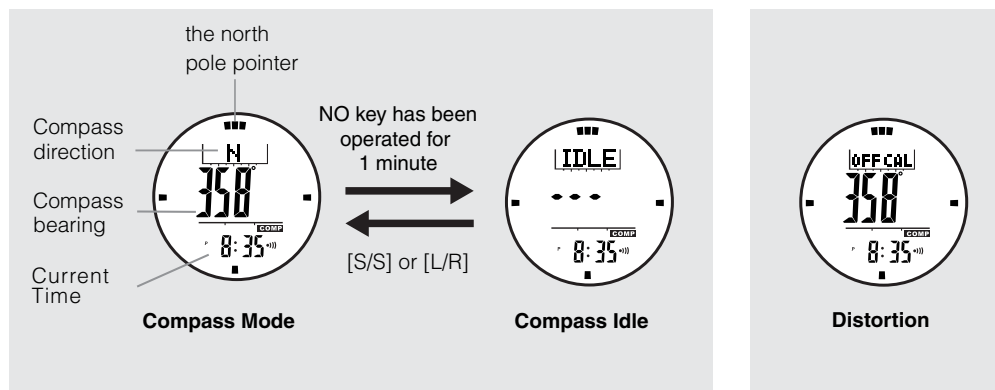

NOTE:

- If NO key has been operated for about 1 minute, the Watch will go to IDLE Mode automatically. Press [S/S] or [L/R] to resume the compass to normal operation .
- If distortion is detected, the compass bearing and compass direction are flashing. See 8.4 to restore the compass to normal operation when distortion occurs.

8.3 Compass Mode - Backward Bearing and Compass Lock

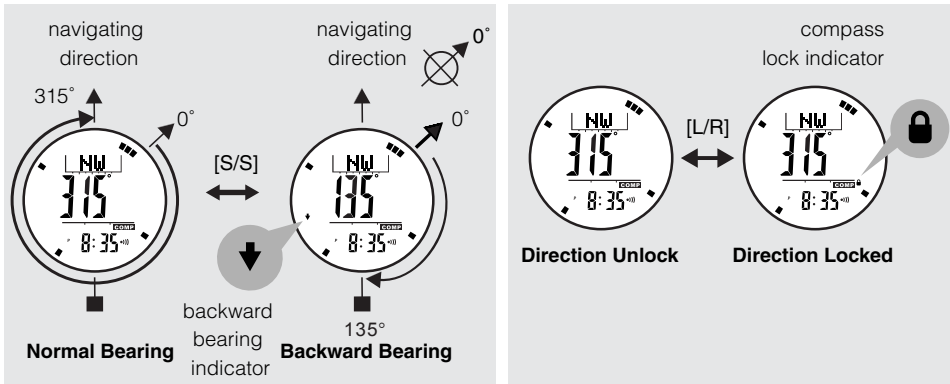

NOTE:

- When the 'Backward Bearing indicator' ↓ is appeared, the Watch is showing the backward bearing direction of the navigating direction.
- When the 'Lock' indicator is appeared, the compass direction, bearing direction and the magnetic north pole pointer are locked and would not be changed.
- The Compass Lock will be released automatically when the Watch enter IDLE Mode.

8.4 Compass Mode - Calibrating the Compass

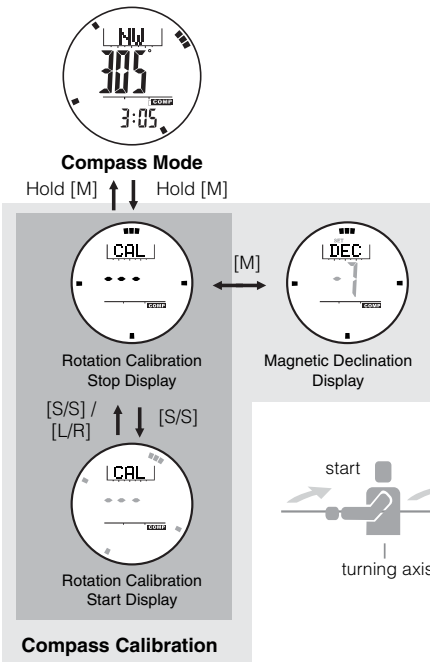

Calibration Display

- In Compass Mode, press and hold [M] to enter Compass Calibration display
- To start rotation calibration, press [S/S] button once. The pointers will start rotating, turn the watch (keep parallel to the horizon) in the same direction of the rotation pointers for more than 2 turns.
- Press [S/S] or [L/R] button to stop the calibration when the 2-turn rotation calibration is completed.
- When the pointer stop rotation, hold [M] button to back to the Compass Mode or press [M] button once to set the magnetic declination.

8.5 Compass Mode - Setting Magnetic Declination

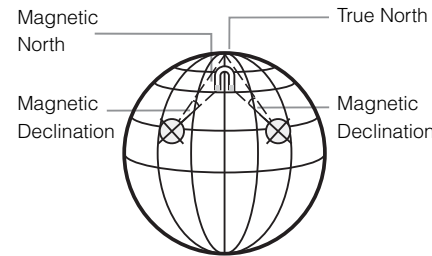

What is Magnetic Declination

- The Magnetic North Pole which is slightly different from the True North Pole. This Watch, like most magnetic compass, points to the Magnetic North Pole, while everything measure from a map is related to the True North Pole.
- The angular difference between Magnetic North Pole and True North Pole is called magnetic declination. Its amount (degrees and minutes) and direction (easterly and westerly) depend on where you are in the world.
- For serious compass user or whom intends to perform accurate navigation, this Watch must be adjusted for magnetic declination.

Magnetic Declination Information

- Most topographic maps include a small arrow which shown magnetic north pole and or the magnetic declination information.
- This manual includes the magnetic declination for some major cities. See the coming chapter 'Magnetic Declination at Major Cities' for more detail.
- For the cities are not included in the list, please refer to the online magnetic declination calculator at:
 - http://geomag.nrcan.gc.ca/apps/mdcal_e.php
 - <http://www.ngdc.noaa.gov/seg/geomag/jsp/Declination.jsp>

8.6 Compass Mode - Magnetic Declination at Major Cities

No.	Country/Place	Major City	Declination	No.	Country/Place	Major City	Declination
1	Afghanistan	Kabul	2-E	33	Netherlands	Amsterdam	1-W
2	Australia	Canberra	12-E	34	New Zealand	Wellington	22-E
3	Austria	Vienna	2-E	35	Norway	Oslo	0
4	Bahrain	Manama	2-E	36	Pakistan	Islamabad	2-E
5	Bangladesh	Dhaka	0	37	Philippines	Manila	1-W
6	Belgium	Brussels	1-W	38	Portugal	Lisbon	5-W
7	Brazil	Brasilia	19-W	39	Russia	Moscow	9-E
8	Canada	Ottawa	14-W	40	Singapore	Singapore	0
9	Chile	Santiago	5-E	41	South Africa	Cape Town	23-W
10	China	Beijing	6-W	42	Spain	Madrid	3-W
11	China	Hong Kong	2-W	43	Sweden	Stockholm	3-E
12	Costa Rica	San Jose	0	44	Switzerland	Bern	0
13	Cuba	Havana	3-W	45	Taiwan	Tai-pei	3-W
14	Czech Republic	Prague	2-E	46	Thailand	Bangkok	0
15	Denmark	Copenhagen	1-E	47	UAE	Abu Dhabi	1-E
16	Egypt	Cairo	3-E	48	United Kingdom	London	3-W
17	Finland	Helsinki	6-E	49	United States	Washington, DC	10-W
18	France	Paris	1-W	50		Juneau	25-E
19	Germany	Berlin	1-E	51		Phoenix	12-E
20	Greece	Athens	3-E	52		Little Rock	2-E
21	Hungary	Budapest	4-E	53		Sacramento	16-E
22	India	New Delhi	1-E	54		Denver	10-E
23	Indonesia	Jakarta	1-E	55		Atlanta	4-W
24	Israel	Jerusalem	3-E	56		Honolulu	10-E
25	Italy	Rome	1-E	57		Boston	16-W
26	Japan	Tokyo	7-W	58		Saint Paul	2-E
27	Jordan	Amman	3-E	59		Jackson	1-E
28	Kenya	Nairobi	1-E	60		Santa Fe	10-E
29	Korea	Seoul	7-W	61		Oklahoma City	6-E
30	Malaysia	Kuala Lumpur	1-E	62		Salem	18-E
31	Mexico	Mexico City	6-E	63		Harrisburg	11-W
32	Nepal	Kathmandu	0	64		Salt Lake City	14-E

8.7 Compass Mode - Magnetic Declination Mode



Compass Mode

Hold [M] ↑ ↓ Hold [M]

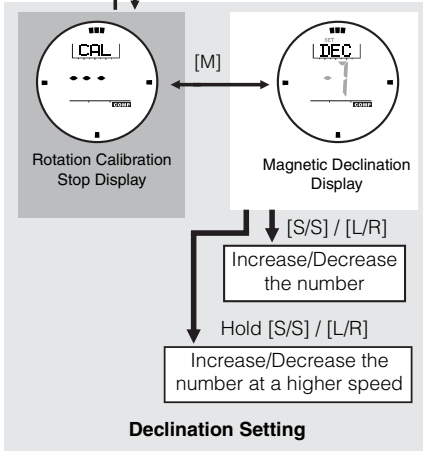

What is Magnetic Declination

- Check the "Magnetic Declination at Major Cities" to get the magnetic declination of the city which is close to your current position. That angle will be inputted into the Watch during the calculation.
- In Compass Calibration display, press [M] to enter Magnetic Declination Display.
- Press [S/S] or [L/R] button to increase / decrease the number. (Hold down the button changes the number at a higher speed)
- Hold [M] to confirm and exit the adjustment display

9.1 World Time Mode - City Initial Code Table

1. ADL Adelaide	11. BRU Brussels	21. DEN Denver	31. KHI Karachi	41. NOU Noumea	51. SIN Singapore
2. AKL Auckland	12. BUE Buenos Aires	22. DUB Dublin	32. LAX Los Angeles	42. NYC New York	52. STO Stockholm
3. AMS Amsterdam	13. CAI Cairo	23. DXB Dubai	33. LIM Lima	43. OSL Oslo	53. SYD Sydney
4. ANC Anchorage	14. CAS Casablanca	24. FRA Frankfurt	34. LIS Lisbon	44. PAR Paris	54. TPE Taipei
5. ATH Athens	15. CCS Caracas	25. HEL Helsinki	35. LON London	45. RIO Rio De Janeiro	55. TYO Tokyo
6. BCN Barcelona	16. CHI Chicago	26. HKG Hong Kong	36. LUX Luxembourg	46. ROM Rome	56. VIE Vienna
7. BER Berlin	17. CPH Copenhagen	27. HNL Honolulu	37. MEL Melbourne	47. SCL Santiago	57. YTO Toronto
8. BJS Beijing	18. CPT Cape Town	28. IST Istanbul	38. MEX Mexico	48. SEL Seoul	58. YVR Vancouver
9. BKK Bangkok	19. DAC Dhaka	29. JKT Jakarta	39. MNL Manila	49. SFO San Francisco	59. ZRH Zurich
10. BOM Mumbai	20. DEL New Delhi	30. JRS Jerusalem	40. MOW Moscow	50. SHA Shanghai	60. MY CITY Selectable

City Code Table

9.0 World Time Mode - Function Display

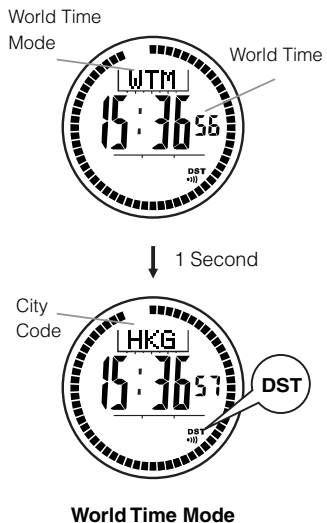

View the World Time

- Press [M] button until enter World Time Mode.
- Press the [S/S] or [L/R] button to select the world time city. The city name will be shown firstly and then show the city initial code with UTC afterwards.

Toggle the Daylight Saving Time (DST)

- Hold down the [L/R] button to toggle the daylight saving time On/ Off.
- When Daylight Saving Time is On, one hour will be adjusted (added) for this setting.

9.2 World Time Mode - Setting

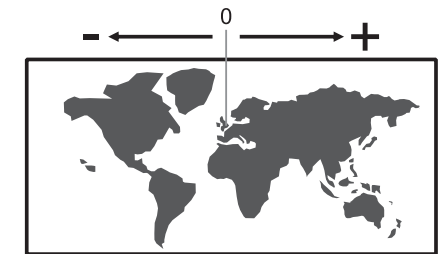
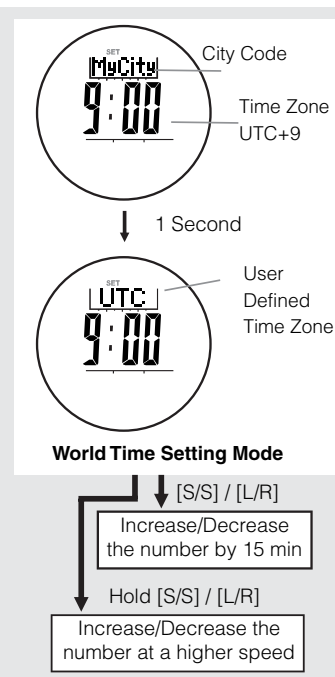

About UTC (Coordinated Universal Time)

- Since the sun shines time on different places is different. Therefore, our world is divided in to several time zones so that people in different places can get a more accurate and common time.
- All the time zone calculations are relative to coordinated Universal Time (UTC). For example, the time zone of London is 'UTC +0'. Los Angeles is 8 hours behind the time of UTC. Therefore, Los Angeles' time zone is 'UTC-8'.

Setting of the User - defined city

- In World Time Setting Mode, press and hold [M] to enter World Time Setting Mode display. Press the [S/S] / [L/R] button in step of 15 minutes to set the correct UTC.
- When setting is completed, hold down the [M] button to finish.

10.0 Timer Mode - Setting the Target Time

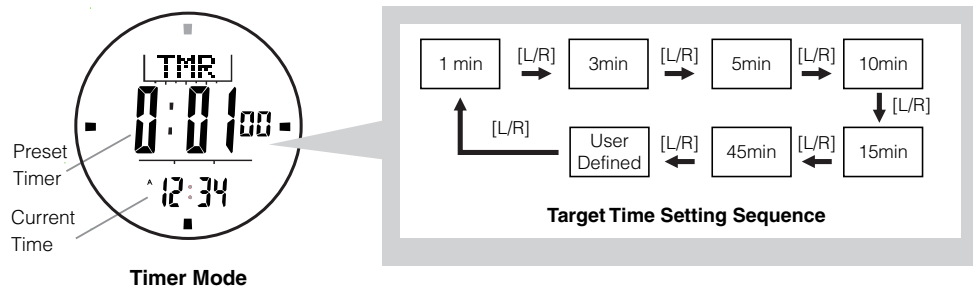

NOTE:

- The Timer starts counting from the Target Time to zero.
- The Watch includes 6 Quick-Set-Values : 1,3, 5, 10, 15 and 45 minutes setting the Target Time faster.
- The User Target Time can be set by user, see 10.1 for the details of the setting.

10.1 Timer Mode - Setting the User Target Time

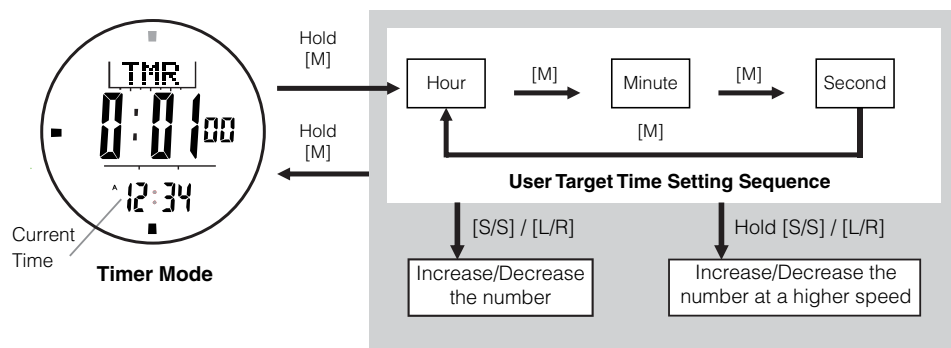

NOTE:

- The setting range is up to 99 hours 59 minutes 59 seconds.

10.2 Timer Mode - Using the Countdown Timer

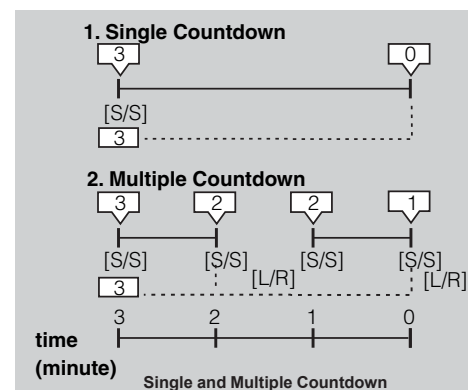

NOTE:

- The Watch will prompt (during the counting) as follows:
 - Beep once every minute for the last 10 minutes, i.e 10'00", 9'00" and etc.
 - Beep once every 10 seconds for the last minute, i.e 0'50", 0'40" and etc.
 - Beep once every seconds for the last 5 seconds.
 - Beep for 30 seconds when timer reaches zero (Press any button CAN stop the beep instantly).
- The Target Time will be reloaded automatically.

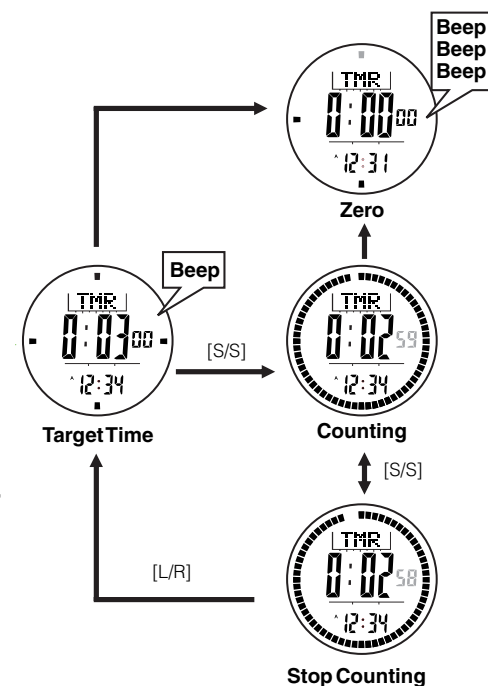

11.0 Power Saving Mode



Current Time Mode

Any Button ↑ ↓ Hold [L/R]

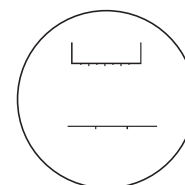

Power Saving Mode

Power Saving Mode

- This Watch has a Power Saving Function which can turn Off the LCD display so that the battery can last longer.
- In the Power Saving Mode, the watch function is still working normally. (i.e. The timekeeping function is still running in Power Saving Mode.)

How to enter/exit the Power Saving Mode

- To enter the Power Saving Mode, hold down the [L/R] button in Current Time Mode for about 5 seconds and the LCD display will be turned Off.
- Press any Button in Power Saving Mode to exit this mode and the LCD display will be resumed.

12.0 Battery - Low Battery Indication

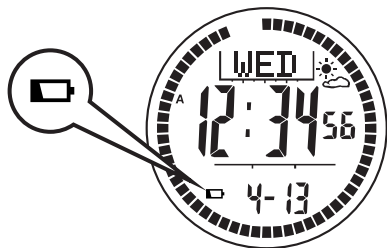

Note:

Replace the battery with a new CR2032.

- However, if the appearance of battery-low indicator is caused by using the Watch under very cold condition, the indicator will be disappeared when normal temperature returns.
- It is recommended to complete the battery replacement by a certified service agency, because this Watch contains precise electronic sensors and components.
- The memory will be cleared if the battery has been replaced.
- See 8.4 to calibrate the compass before using the Compass again.

13.0 Specifications - Timekeeping Mode

Current Time Mode

- Hour, minute, second, am, pm, month, date
- Day of week, weather forecast, temperature, sea level pressure history display or altitude history.
- Time System: 12-hour or 24-hour format
- Daylight Saving Time (DST)

Calendar System

- Auto-Calendar pre-programmed from the year 2000 to 2099
- Weather Forecast: 5 symbols to indicate the predicated weather

Daily Alarm Mode

- 2 daily alarms
- Hourly chime
- Alarm Sound
- Sounds for 30 seconds at preset time

Countdown Timer Mode

- Resolution: 1 second resolution
- Measuring range: 99 hours 59 minutes 59 seconds
- Quick Set : 6 quick set Values (1, 3, 5, 10, 15, 45 minutes) and 1 User Define.

Timer Sounds:

- Last 10 minutes beep once every minute
- Last 1 minute beeps once every 10 seconds
- Last 5 seconds beeps once every second
- Sounds for 30 seconds when count to zero

World Time Mode

- Preset Time Zone: 59 cities
- Time Zone setting range (GMT): -13:00 ~ +13:00

13.1 Specifications - Sensor Mode

Trip Mode - Pedometer

- 3 Target Goal: Distance, Steps and Calories
- Step range: 0-999999
- Moving Timer: 0:00:00 to 9:59:59
- Distance Measurement: max. 99 km
- Speed Measurement: max. 65 km/h
- Maximum 30 Trip point data recall
- Maximum 10 Peak Points recall

Trip Mode - Altimeter

- Resolution : 1m (1ft)
- Measuring range: -706m to 9164m (-2316ft to 30067ft)
- Sampling Interval: First 5 min: 1 sec; After 5 min: 1 minute

Barometer Mode

- Resolution/ Measuring Range: 300 hPa/mbar to 1100 hPa/mbar (8.85 inHg to 32.48 inHg)
- Sampling Interval : First 5 min: 1 second; After 5 min: 1 min
- History Recall: Maximum 24 hours history recall

Thermometer

- Resolution: 0.1 °C (0.1°F)
- Measuring range: -10.0 °C to 60.0 °C (14.0 °F to 140.0 °F)

Compass Mode

- Resolution: 16 display (digital)
- Measuring range: 0° to 359° (digital)
- Others: Digital bearing reading Lock
- Digital backward bearing
- Declination Setting: Range: +90° to -90°

Backlight

- Electro-Luminescent (EL) backlight

Battery

Watch: 3V lithium battery (CR2032) 1 piece



Instruction Manual